

Lebus® Load Binders

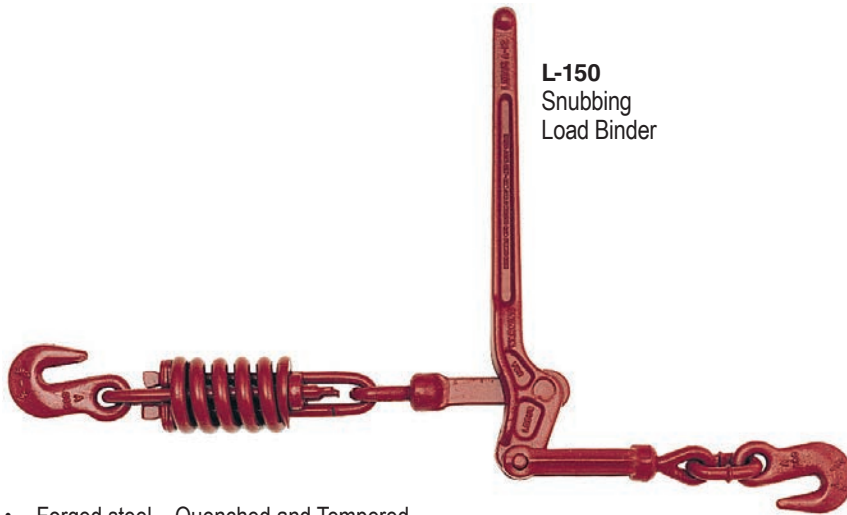

L-150
Snubbing
Load Binder

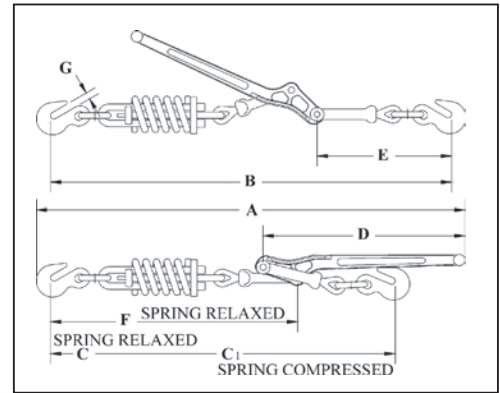

- Forged steel – Quenched and Tempered.
- Spring cushion for load protection, cushions shock and sway.
- Binder toggles away from the load.

SEE APPLICATION AND WARNING INFORMATION
On Pages 271
Para Español: www.thecrosbygroup.com



L-150 Snubbing Load Binders

Model	Stock No.	Min-Max Chain Size (mm)	Working Load Limit (t)	Ultimate Load (t)	Weight Each (kg)	Handle Length (mm)	Take Up (mm)	Compression Strength of Spring (kg)	Dimensions (mm)							
									A	B	C	C1	D	E	F	G
7-12	1048280	8 - 10	2.45	7.27	5.10	406	108	1040	832	781	711	673	406	264	483	12.7
A-12	1048306	10 - 13	4.17	9.09	8.48	470	114	1500	945	864	749	773	475	313	530	16.0

Chain & Accessories

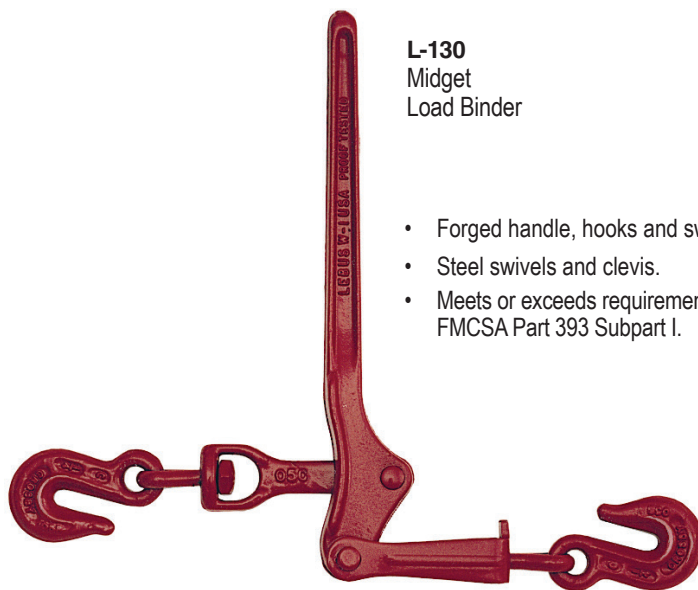

L-130
Midget
Load Binder

- Forged handle, hooks and swivel link.
- Steel swivels and clevis.
- Meets or exceeds requirements of US DOT FMCSA Part 393 Subpart I.

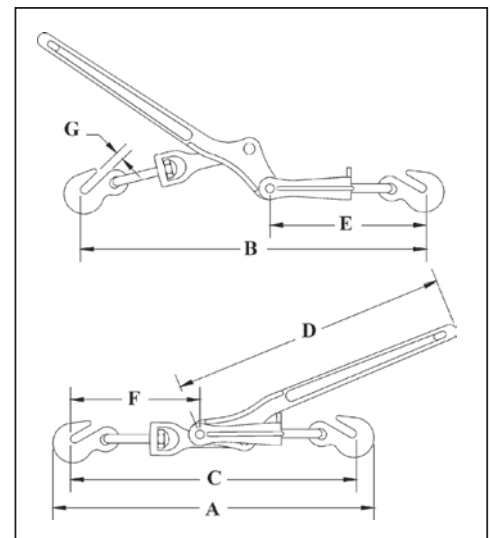

L-130 Midget Load Binders

Model	L-130 Stock No.	Min-Max Chain Size (mm)	Working Load Limit (t)	Ultimate Load (t)	Weight Each (kg)	Take Up (mm)	Dimensions (mm)						
							A	B	C	D	E	F	G
W-1	1048100	5 - 6	.66	2.31	1.17	61.0	410	346	279	286	159	167	8.65