

Lebus® Load Binders

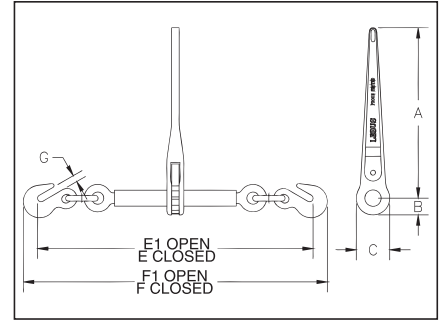

L-140
Ratchet Type
Load Binder

- Upgraded for use with Grades 70, 80 and 100 Chain.
- Utilizes standard Crosby A-323 Alloy Eye Grab Hooks.
- New design “one piece” forged handle.
- Continuous take-up feature provides finite adjustment to tie down load.
- One piece assembly, no bolts or nuts to loosen.
- Ratchet spring is rust proofed.
- All load bearing or holding parts forged.
- Easy operating positive ratchet.
- Binders shown with Proof Loads have been individually proof tested to values shown, prior to shipment.
- Meets or exceeds requirements of US DOT FMCSA Part 393 Subpart I.



Load Rated®

L-140 Standard Ratchet Type Load Binders

Model	Stock No.	Min-Max Chain Size (mm)	Working Load Limit (t)*	Proof Load (kN)	Weight Each (kg)	Handle Length (mm)	Barrel Length (mm)	Take Up (mm)	Dimensions (mm)							
									A	B	C	E	E1	F	F1	G
R-7 **	1048404	8 - 10	4.00	79	5.49	356	254	203	356	35.1	70.0	583	786	638	842	12.7
R-A **	1048422	10 - 13	6.80	134	6.66	356	254	203	356	35.1	70.0	641	845	702	905	16.0
R-C ***	1048440	13 - 16	7.26	143	6.60	356	254	203	356	35.1	70.0	670	873	748	951	18.3

* Ultimate Load is 3 times the Working Load Limit. ** Matches the Working Load Limit of Grade 100 chain for both sizes. *** Matches the Working Load Limit of Grade 100 chain for 13mm size.

Chain & Accessories



R-7QL
Ratchet Type
Load Binder

- For use with Grade 7 Transport Chain.
- Utilizes standard Crosby A-323 Alloy Eye Grab Hooks.
- New design “one piece” forged handle.
- Continuous take-up feature, infinite adjustment, gets the last half of chain.
- One piece assembly, no bolts or nuts to loosen.
- Ratchet spring is rust proofed.
- All load bearings or holding parts forged.
- Easy operating positive ratchet.
- Binders shown with Proof Loads have been individually proof tested to values shown, prior to shipment.

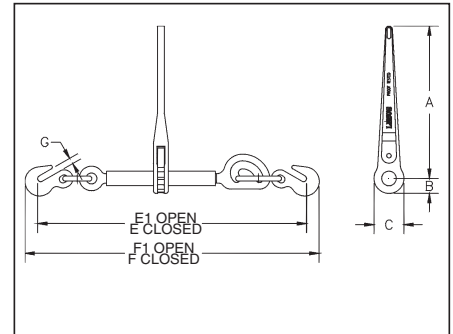

Load Rated®

R-7QL QUIC-LINK Ratchet Load Binder

Model	Stock No.	Min-Max Chain Size (mm)	Working Load Limit (t)*	Proof Load (kN)	Weight Each (kg)	Handle Length (mm)	Barrel Length (mm)	Take Up (mm)	Dimensions (mm)							
									A	B	C	E	E1	F	F1	G
R-7QL	1048413	8 - 10	3.00	59	5.56	356	254	203	356	35.1	70.0	630	833	686	889	12.7

* Ultimate Load is 3 times the Working Load Limit.