



Premium Elektrisk kædetalje DEH / Premium Electric Chain Hoist DEH

NYHED

2.
generation /
2nd
generation
-2022-ekstraudstyr/
optional

Egenskaber

- » Robust konstruktion
- » Velegnet til en lang række industrielle applikationer.
- » Svirvel lastkrog med sikkerhedspal
- » Let at adskille til vedligeholdelsesformål.
- » Kontrolsystem med relæer fra EATON eller SIEMENS.
- » Transmission med permanent smøring sikrer jævn og stille drift.
- » Leveres med styretryksbetjening, strømkabel og kædepose.
- » I overensstemmelse med maskindirektiv 2006/42/EF. Leveres med testcertifikat CE-overensstemmelseserklæring samt brugervejledning.

Features

- » Robust housing.
- » Suitable for a wide range of industrial applications.
- » Swivel load hook with safety latch.
- » Easy to disassemble for maintenance purposes.
- » Control system with SIEMENS / EATON relays.
- » Permanently lubricated transmission, ensures smooth and quiet operation.
- » Supplied with control switch, power cable and chain container.
- » Complies with the Machinery Directive 2006/42/EC. Supplied with test certificate, CE declaration of conformity and operating instructions.

RUD
lastkæde
load chain

DH.0.DEH

Specifikationer / Specifications

Artikel nummer Article code	Kapacitet Capacity ton	Hejsehastighed Lifting speed m/min	Lastkæde Load chain Øxmm	Antal kædestreng Chains falls	Energiforbrug Power output kW	Netto vægt Net weight kg	Extra vægt Extra weight kg/m
DH.0.DEH.001253	0.125	8/2	4 x 12	1	0.4/0.1	22	0.4
DH.0.DEH.002503	0.25	8/2	4 x 12	1	0.4/0.1	22	0.4
DH.0.DEH.00503	0.5	8/2	5 x 15	1	0.72/0.18	33	0.7
DH.0.DEH.01003	1	8/2	7.1 x 21	1	1.6/0.4	56	1.1
DH.0.DEH.02003	2	4/1	7.1 x 21	2	1.6/0.4	58	2.2

Specifikationer / Specifications

Voltage / Operating voltage	400-440V / 50Hz / 3Ph	(kun 400V med elektrisk løbekat / with electric trolley only 400V)
Hejsehastighed / Lifting speed	To løftehastigheder / Double speed	
Lastkæde / Load chain	Lastkæde i henhold til EN 818-7-DAT/DT / Load chain according to EN 818-7-DAT/DT	
Styretrykskabel / Control cable	Standard ≈6 meter / Standard ≈6 meter	
Strømkabel / Power cable	≈1 meter uden stik / ≈1 meter without plug	
IP klassificering (hus) / Housing protection	IP 55	
IP klassificering (styretryk) / Control protection	IP 65	
Klassifikation / Classification	M5/2m (ISO/FEM)	
Driftscyklus / Start pr. time / Duty cycle / Starts per hour	40% / 240	
Isolationsklasse / Insulation class	F	
Drifttemperatur / Operating temperature	-10°C - +40°C	
Byrde type / Load type	Varer, må ikke anvendes til løft af mennesker / Goods, may not be used to lift people	

Beskyttelse / Protection

Kontrolafbryder / Control switch	24V styrkebetjening med nødstop / 24V pendant control switch with emergency stop button
Overlastsikring / Overload protection	Udvendigt indstilling glidekobling samt digital sikring / Externally adjustable slip clutch
Bremse / Brake	Elektromagnetisk fjeder trykbremse, holder byrden i tilfælde af strømsvigt / Electromagnetic spring pressure brake, holds the load in the event of power failure
Endestopkontakt / Limit switch	Elektromekanisk endestop øverst og nederst / Electro-mechanical upper and lower limit switch
Beskyttet gennem armesensor / Thermal protection	Beskyttet gennem varmesensor / Protected through heat sensor



Premium Elektrisk kædetalje DEH / Premium Electric Chain Hoist DEH



Se produktvideoen!
Watch the product video!

**Klik på linket * click on the link **



Nederlands

<https://youtu.be/zyZp5x0Ogd8>



English

<https://youtu.be/PmDD7nsrIGw>



Deutsch

<https://youtu.be/hD-nbCQm3P8>



Français

<https://youtu.be/JInvP16ODNw>



Español

<https://youtu.be/00VBnFyTmB0>



Italiano

<https://youtu.be/Yp41sYjcEyw>



Dansk

<https://youtu.be/f1ZN2H3hfcc>



Suomalainen

<https://youtu.be/pGAGfRgnhuk>



Premium Elektrisk kædetalje DEH / Premium Electric Chain Hoist DEH

NYHED



DH.0.DET.LLS

ekstraud-
styr

DH.0.DED

ekstraud-
styr

DH.0.DEY

Egenskaber

- » Elektrisk kædetalje monteret på elektrisk løbekat med lav indbygningshøjde.
- » Løbekatten er udstyret med hjul der giver optimal balance og giver nem kørsel pålangs af bjælken.
- » Sikkerhedsstænger fungerer som flad-, brud, og stødbeskyttelse. Derudover er modellerne også udstyret med vippebeskyttelse
- » Hjul med permanent smørelse og kuglelejer for nem kørsel
- » Velegnet til de fleste I- og H- bjælkeprofiler.

Features

- » Electric chain hoist mounted on low headroom (electric) trolley.
- » Balance support wheels enable smooth travelling along the beam.
- » Safety bars serve as fall-, breaking- and impact protection. Additionally equipped with tilting protection.
- » Permanently lubricated, ball bearing mounted wheels allow for smooth traversing.
- » Suitable for most I- and H-beam profiles.

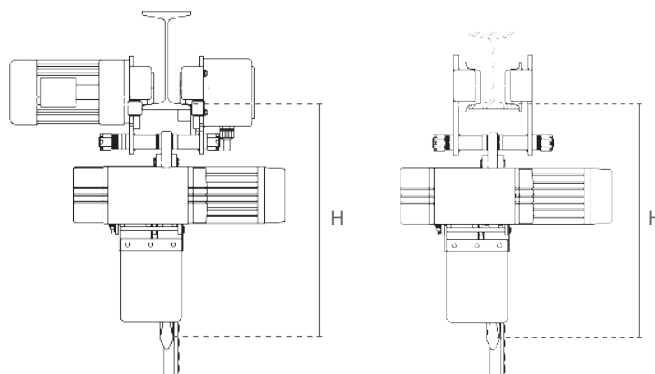

Specifikationer / Specifications						
Varenummer	Kapacitet	Kørehastighed	Energiforbrug løbekat	Bredde	Netto vægt	Min. højde (H)
Article code	Capacity	Traversing speed	Power output trolley	Beam width	Net weight	Min. height (H)
DH.0.DED.001253	0.125	20/6.7	0.2/0.07	74-300	55	438
DH.0.DED.002503	0.25	20/6.7	0.2/0.07	74-300	55	438
DH.0.DED.00503	0.5	20/6.7	0.2/0.07	74-300	66	480
DH.0.DED.01003	1	20/6.7	0.2/0.07	74-300	89	578
DH.0.DED.02003	2	20/6.7	0.4/0.13	74-300	98	670

Specifikationer / Specifications				
Varenummer	Kapacitet	Bredde	Netto vægt	Min. Højde (H)
Article code	Capacity	Beam width	Net weight	Min. height (H)
DH.0.DEY.001253	0.125	74-300	29	438
DH.0.DEY.002503	0.25	74-300	29	438
DH.0.DEY.00503	0.5	74-300	40	480
DH.0.DEY.01003	1	74-300	63	578
DH.0.DEY.02003	2	74-300	70	670



Premium Elektrisk kædetalje DEH / Premium Electric Chain Hoist DEH

Nem udskiftelige relæer monteret på stålplade / Easily exchangeable relays mounted on a steel plate

NY 2022

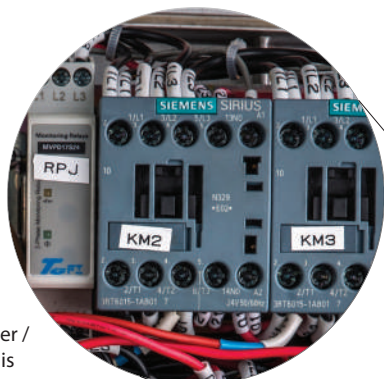

SIEMENS relæer / Reliable relays

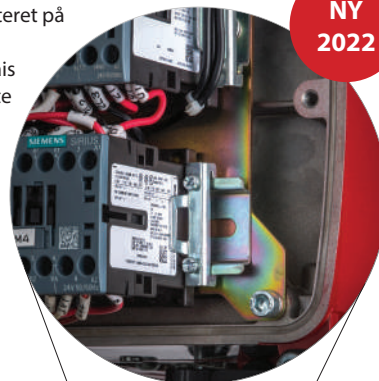

 EATON
125 kg
250 kg

 SIEMENS
500 kg
1000 kg
2000 kg

NY 2022



Nemme plug&play-tilslutninger / Easy plug&play connections

2. generation / 2nd generation -2022-

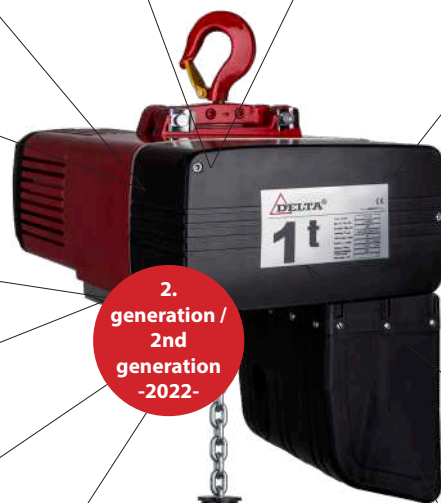

NY 2022



Kæde og endestop i høj kvalitet / High quality, durable chain end buffer



Øvre og nedre begrænset af mikro switch / Upper and lower limit micro switch



Premium Elektrisk kædetalje DEH / Premium Electric Chain Hoist DEH



Nem tilgængelig og justerbar glidekobling
/Easily reachable and adjustable slip clutch



RUD® lastkæde/
RUD® load chain

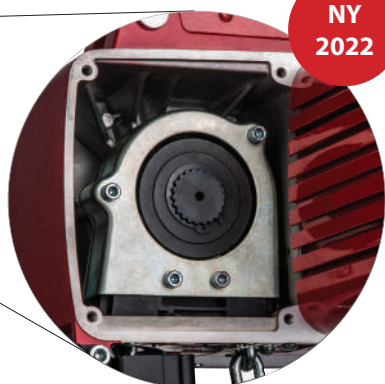

Kædestyr er let tilgængelig for vedligeholdelse /
Chain guide easily accessible for maintenance purposes



Opdateret ergonomisk kontrol /
Updated ergonomic control

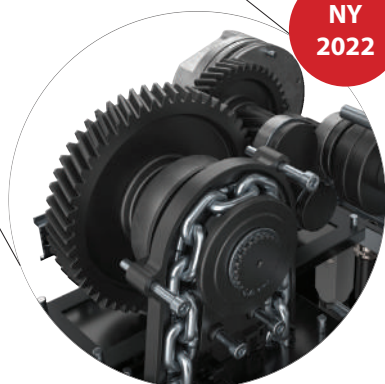

Opdateret gearkasse /
Updated gearbox



Opdateret kædepose /
Updated chain bucket



Premium Elektrisk kædetalje DEH / Premium Electric Chain Hoist DEH

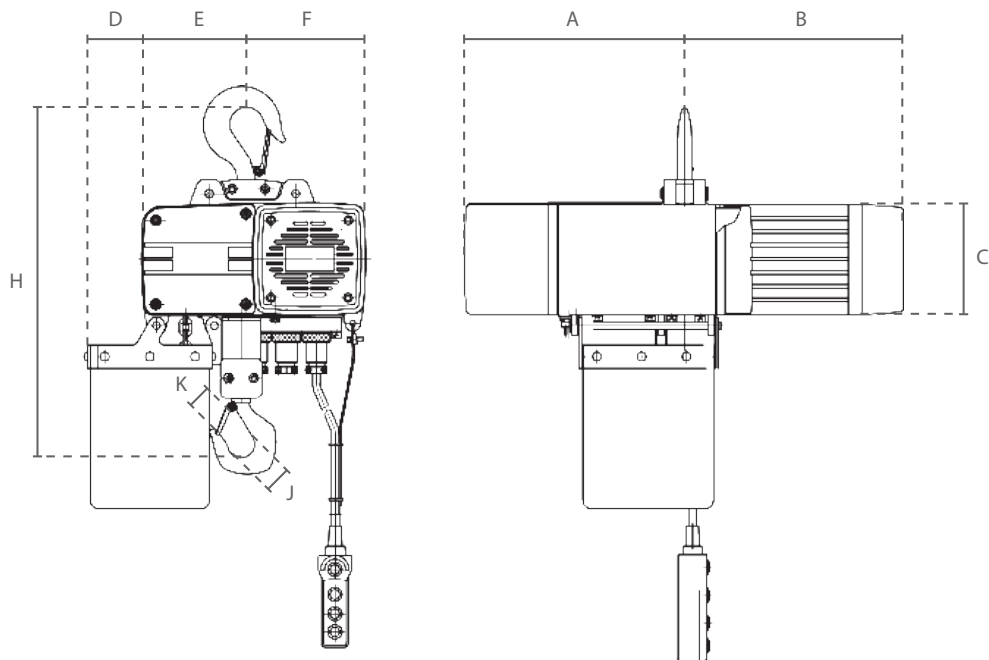

Dimensioner / Dimensions									
Varenummer Article code	A	B	C	D	E	F	H	J	K
DH.0.DEH.001253	211	228	115	57	114	123	420	40	23
DH.0.DEH.002503	211	228	115	57	114	123	420	40	23
DH.0.DEH.00503	231	204	165	62	118	162	465	40	27
DH.0.DEH.01003	264	245	175	67	128	187	575	45	31
DH.0.DEH.02003	264	245	175	89	150	165	690	53	38

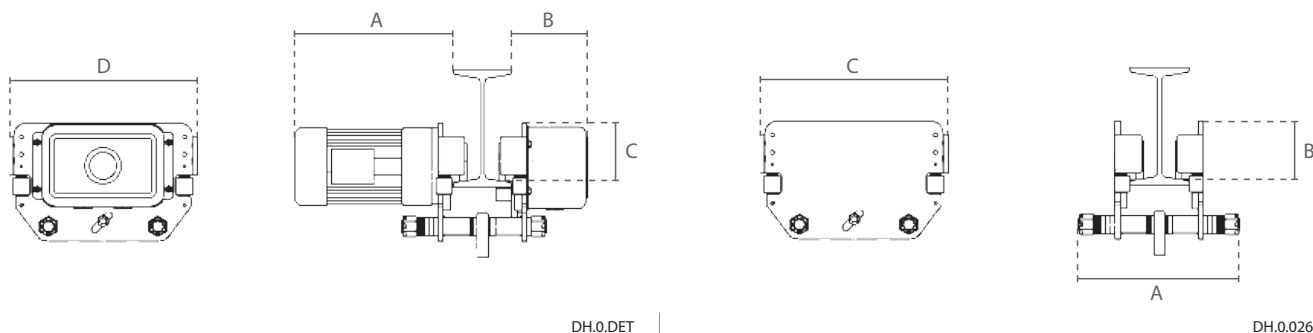

DH.0.DET

DH.0.026

Specifikationer / Specifications					Dimensioner / Dimensions			
Referencenummer Article code	Kapacitet Capacity	Min. radius Min. radius	Diameter på hjul Wheel diameter	Netto vægt Net weight	A	B	C	D
DH.0.DET.0122	0.125	2.5	68	33	336	131	97	320
DH.0.DET.0252	0.25	2.5	68	33	336	131	97	320
DH.0.DET.0502	0.5	2.5	68	33	336	131	97	320
DH.0.DET.1002	1	2.5	68	33	336	131	97	340
DH.0.DET.2002	2	2.5	75	40	338	132	113	340

Specifikationer / Specifications					Dimensioner / Dimensions		
Varenummer Article code	Kapacitet Capacity	Min. radius Min. radius	Diameter på hjul Wheel diameter	Netto vægt Net weight	A	B	C
DH.0.02600125	0.125	2.5	68	7	424	75	270
DH.0.02600250	0.25	2.5	68	7	424	75	270
DH.0.02600500	0.5	2.5	68	7	424	75	270
DH.0.02601000	1	2.5	68	7	424	75	270
DH.0.02602000	2	2.5	75	12	424	75	270